

NAME	JOSH	TEMP	85°F	ENGINE	SIRIO	MUFFLER	Kyosh	MANIFOLD	Kyosh
DATA	APRIL 14, 2004	HUMIDITY	Low %	HEAD CLEARANCE	.50 mm	FUEL TYPE	30%		
TRACK	Las Vegas	TRACTION	Med %	PLUG No.	7	RADIO	K6 HELIOS		

FRONT

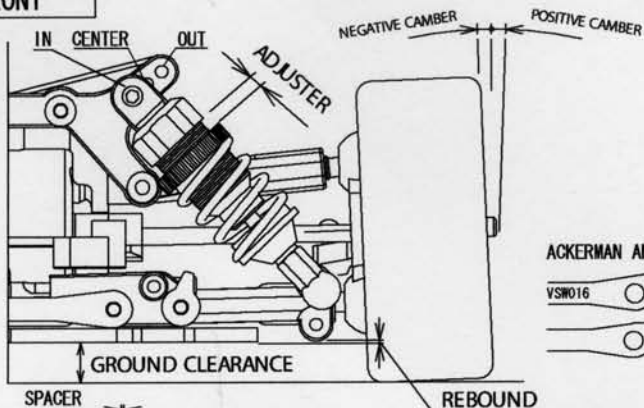

SHOCK OIL	300 350 400 450 500 550 600 700
SHOCK PISTON	N Stock
SPRING	S (B) G Black
SPRING ADJUSTER	4.5 mm
SHOCK POS	(IN) CENTER OUT
CASTER ANGLE	6° 0 mm
CAMBER ANGLE	OG/1G 0 0.5 1.0 (1.5) 2.0
TOE ANGLE	2° out
FRONT WIDTH	199 mm
REBOUND STOP	0 mm
STABILIZER BAR	
TIRE TYPE	40 SHORE
TIRE SIZE	φ 60 mm
WHEEL	JACO
GROUND CLEARANCE	4 mm



CASTER ANGLE	
2mm	10°
1mm	8°
0mm	6°

DIFF. /	(ONEWAY)
RING GEAR	(39T) 40T
ACKERMAN ANGLE	A B (C)
ST D/R	%

REAR

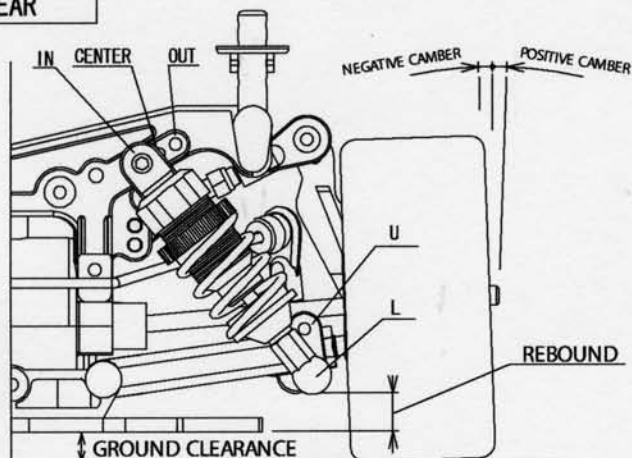

SHOCK OIL	300 350 400 450 (500) 550 600 700
SHOCK PISTON	N Stock
SPRING	S B G 1.8 KYOSHO WHITE
SPRING ADJUSTER	1.5 mm
SHOCK POS	(IN) CENTER OUT
SHOCK POS	(U) / L
UPPER ARM POS	IN (U/L) - OUT (U/L)
CAMBER ANGLE	OG/1G 0 0.5 1.0 1.5 2.0 (2.5) 3.0
TOE ANGLE	1.5°
REAR WIDTH	198 mm
REBOUND STOP	4 mm
STABILIZER BAR	SILVER (BLACK) GOLD
REAR SUS. HOLDER	(H) L
DIFF OIL	# 10,000
TIRE TYPE	40 SHORE
TIRE SIZE	φ 60 mm
WHEEL	JACO
GROUND CLEARANCE	4 mm
BODY	Losi ALPHA
BODY POSITION	?
REAR SPOILER HEIGHT	LEVEL TO ROOF
REAR SPOILER ANGLE	STANDARD
GEAR	20 (21) 22 / 25 26 (27)
GEAR	(50) 51 / (45) 46
RING GEAR	(39T) 40T
CLUCH SHOE	GREY

RING GEAR 39T				
GEAR	TOTAL	GEAR	TOTAL	
20	50	25	45	5.40
20	51	25	46	5.52
21	50	26	45	5.19
21	51	26	46	5.30
22	50	27	45	5.00
22	51	27	46	5.11

RING GEAR 40T				
GEAR	TOTAL	GEAR	TOTAL	
20	50	25	45	5.54
20	51	25	46	5.66
21	50	26	45	5.33
21	51	26	46	5.44
22	50	27	45	5.13
22	51	27	46	5.24

CLUTCH WEIGHT	STANDARD
SPRING	STANDARD
CLEARANCE	.4 mm
ADJ NUT	? mm